

Description:

- High Efficiency
- Advanced SMT Design
- Universal 85-264VAC Input
- Compact 2.5" x 4.5" x 1.2" Size
- Fits 1U Applications
- Optional Chassis and Cover
- EMC Immunity Compliance to EN 61000-6-2, EN 60601-1-2
- EMC Emissions Compliance to EN 55011/22, Class B
- Safety Certified to EN 60950, EN 60601-1-2
- Harmonic Current per EN 61000-3-2

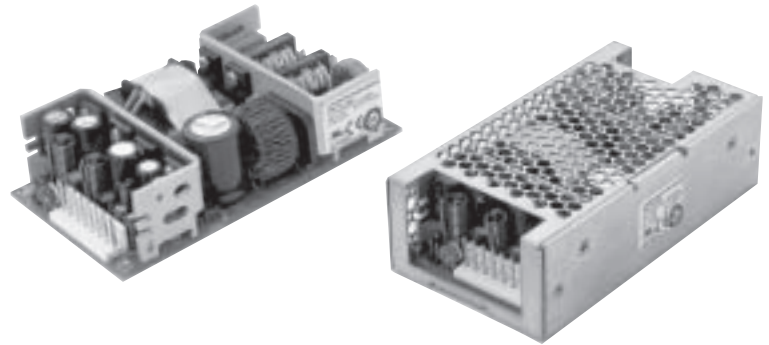

OUTPUT SPECIFICATIONS

Total Output Power at 50°C	50W 70W	Convection Cooled Forced Air Cooled
Output Voltage Centering (50% load)	Output 1: ± 0.5% Output 2: ± 5.0% Output 3: ± 5.0% Output 4: ± 5.0%	
Output Voltage Adjust Range	Output 1: 95 - 105%	
Load Regulation	Output 1: 0.5% (10-100% load change) Output 2: 5.0% (20-100% load change) (4001-5) 8.0% (20-100% load change) (2001) Output 3: 5.0% (20-100% load change) Output 4: 5.0% (20-100% load change)	
Source Regulation	Outputs 1-4: 0.5%	
Cross Regulation	Outputs 2-4: 5.0%	
Output Noise	Source Freq. Outputs 1-4: 0.5% Switching Freq. Outputs 1-4: 1.0% Total (20 MHz) Outputs 1-4: 1.0%	
Turn On Overshoot	None	
Transient Response	Outputs 1-4	
Voltage Deviation	5.0%	
Recovery Time	500µS	
Load Change	50% To 100%	
Output Overvoltage Protection	Output 1: 110% to 150%	
Output Overpower Protection	110-160% rated Pout, cycle on/off, auto recovery	
Hold Up Time	16 mS min., Full Power, 85V Input	
Start Up Time	4 Seconds, 120V Input	

INPUT SPECIFICATIONS

Source Voltage	85 - 264 Volts AC
Frequency Range	47-63 Hz
Peak Inrush Current	40A
Efficiency	78% Typ., Full Power, 230V, varies by model
Power Factor	0.95 (Full Power, 230V)

ENVIRONMENTAL SPECIFICATIONS

Ambient Operating Temperature Range	0° C to +70° C Derating: See Power Rating Chart
Ambient Storage Temperature Range	-40° C to +85° C
Temperature Coefficient	Outputs 1-4: 0.02%/°C
Vibration	MIL-STD-810E, Method 514.4, Category 1
Shock	Transit Drop per MIL-STD-810E Method 516.4 Procedure IV

GENERAL SPECIFICATIONS

Dielectric Strength	5656 VDC, Primary to Secondary, 1 Sec. 2121 VDC, Primary to Ground, 1 Sec. 707 VDC, Secondary to Ground, 1 Sec.
Leakage Current	<300uA Earth Leakage Current <100uA Patient Leakage Current
Power Fail Signal	Logic low with input power failure 10mS minimum prior to output one dropping 1%
Remote Sense (singles only)	250mV compensation of output cable losses
Mean-Time Between Failures	100,000 Hours min., MIL-HDBK-217F, 25° C, GB
Weight	0.60 Lbs. Open Frame 1.00 Lbs. Chassis and Cover





MODEL LISTING

MODEL	OUTPUT 1	OUTPUT 2	OUTPUT 3	OUTPUT 4
REL-70-4001	+3.3V/6A	+5V/5A	+12V/2A ⁽⁶⁾	-12V/2A ⁽⁶⁾
REL-70-4002	+5V/6A	+3.3V/5A	+12V/2A ⁽⁶⁾	-12V/2A ⁽⁶⁾
REL-70-4003	+5V/6A	+3.3V/5A	+15V/2A ⁽⁶⁾	-15V/2A ⁽⁶⁾
REL-70-4004	+5V/6A	-5V/5A	+12V/2A ⁽⁶⁾	-12V/2A ⁽⁶⁾
REL-70-4005	+5V/6A	-5V/5A	+15V/2A ⁽⁶⁾	-15V/2A ⁽⁶⁾
REL-70-4006	+5V/6A	+24V/2A	+12V/2A ⁽⁶⁾	-12V/2A ⁽⁶⁾
REL-70-4007	+5V/6A	+24V/2A	+15V/2A ⁽⁶⁾	-15V/2A ⁽⁶⁾
REL-70-3001	+5V/6A	+12V/2A		
REL-70-3002	+5V/6A	+15V/2A		-15V/2A
REL-70-2001	+3.3V/6A	+5V/5A		
REL-70-2002	+5V/6A	+12V/4A		
REL-70-2003	+5V/6A	+24V/2A		
REL-70-2004	+12V/3A	-12V/3A		
REL-70-2005	+15V/3A	-15V/2A		
REL-70-1001	2.5V/14A			
REL-70-1002	3.3V/14A			
REL-70-1003	5V/14A			
REL-70-1004	12V/5.8A			
REL-70-1005	15V/4.7A			
REL-70-1006	24V/2.9A			
REL-70-1007	28V/2.5A			
REL-70-1008	48V/1.5A			

ELECTROMAGNETIC COMPATIBILITY SPECIFICATIONS

Electrostatic Discharge	EN 61000-4-2	±4kV Contact Discharge ±8kV Air Discharge
Radiated Electromagnetic Field EFT/Bursts	EN 61000-4-3 EN 61000-4-4	26-1000 MHz, 10V/M, 80% AM ±2 kV
Surges	EN 61000-4-5	±2 kV Line to Earth ±1 kV Line to Line
Conducted Immunity	EN 61000-4-6	.15 to 80MHz, 10V, 80% AM
Voltage Dips	EN 61000-4-11	95% Dip, 10ms 30% Dip, 500ms
Voltage Interruptions	EN 61000-4-11	95% Reduction, 5s
Radiated Emissions	EN 55022/11	Class B
Conducted Emissions	EN 55022/11	Class B
Harmonic Current Emissions	EN 61000-3-2	Class A
Voltage Fluctuations and Flicker	EN 61000-3-3	

SAFETY SPECIFICATIONS

 Underwriters Laboratories File E137708	UL 60950 Third Edition UL 2601-1 Second Edition CB Report per IEC 60950(1999) Third Edition including all National Deviations CB Report per IEC 60601-1(1988) Second Edition A1, A2
 UL Recognition Mark For Canada File E137708	CAN/CSA-C22.2 No. 60950-00 CAN/CSA-C22.2 No. 601-1-M90
 TUV	EN 60950/2000 EN 60601-1/A2:1995
	Low Voltage Directive

- 70 Watt Medical / ITE Approved Power Supply
- 1-4 Outputs ranging from 3.3-48 VDC

REL-70 SERIES MECHANICAL SPECIFICATIONS

OPEN FRAME

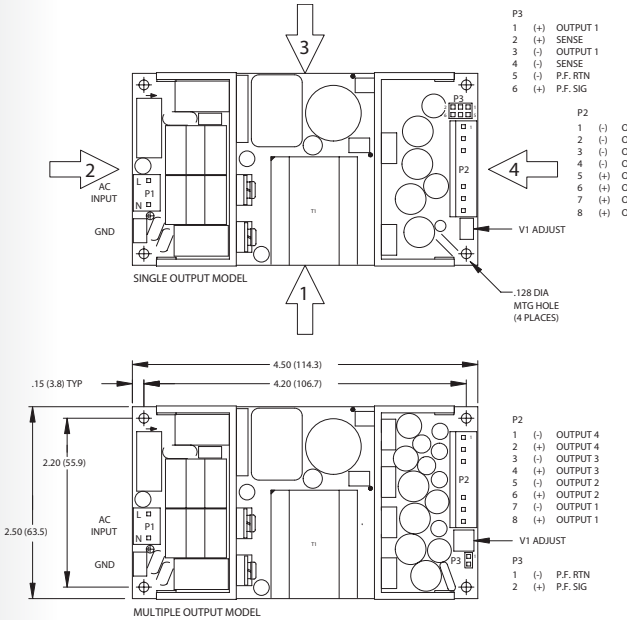

CHASSIS & COVER

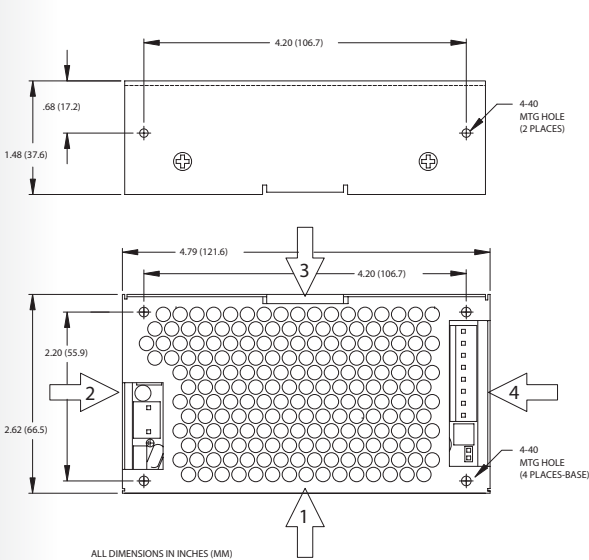

APPLICATIONS INFORMATION

- Total power must not exceed 50 watts with convection cooling on open frame models.
- Total power must not exceed 70 watts with 300LFM forced air cooling on open frame models.
- Total power must not exceed 40 watts with convection cooling and chassis/cover option.
- Total power must not exceed 70 watts with 300LFM forced air cooling and chassis/cover option.
- Each output can deliver its rated current but total output power must not exceed maximum power as determined by the cooling method stated above.
- Rated 1.5 A with convection cooling.
- Sufficient area must be provided around convection cooled power supplies to allow natural movement of air to develop.
- 300 linear feet per minute of airflow must be maintained one inch above any point of the heatsink in the direction shown when forced air cooling is required.
- This product is intended for use as a professionally installed component within information technology and medical equipment.
- A minimum load of 10% is required on output one to ensure proper regulation of remaining outputs.
- Remote sense terminals may be used to compensate for cable losses up to 250mV (single output models only). The use of a twisted pair is recommended as well as a de-coupling capacitor (0.1 - 10µF) and a capacitor of 100µF/amp connected across the load side.
- Peak to peak output ripple and noise is measured directly at the output terminals of the power supply, without the use of the probe ground lead or retractable tip, 20 MHz bandwidth.
- This power supply has been safety approved and final tested using a DC dielectric strength test. Please consult factory before performing an AC dielectric strength test.
- Maximum screw penetration into bottom chassis mounting holes is .100 inches.
- Maximum screw penetration into side chassis mounting holes is .250 inches.
- To meet emissions specifications, all four mounting hole pads must be electrically connected to a common metal chassis. Chassis/cover option recommended.

MAXIMUM OUTPUT POWER VS. AMBIENT TEMPERATURE

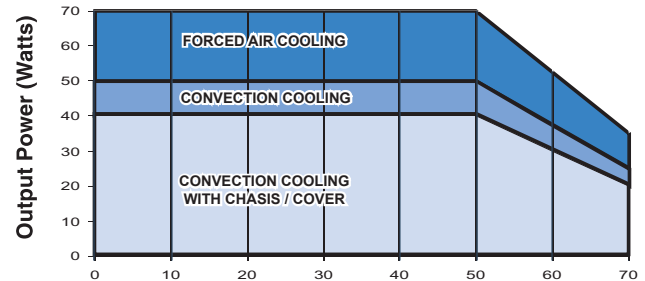

CONNECTOR SPECIFICATIONS

P1	AC Input	.156 friction lock header mates with Molex 09-50-3031 or equivalent crimp terminal housing with Molex 2478 or equivalent crimp terminal.
P2	DC Output (Single)	.156 friction lock header mates with Molex 09-50-3081 or equivalent crimp terminal housing with Molex 2478 or equivalent crimp terminal.
P2	DC Output (Multiple)	.156 friction lock header mates with Molex 09-50-3081 or equivalent crimp terminal housing with Molex 2478 or equivalent crimp terminal.
G	Ground	.187 quick disconnect terminal.
P3	P.F./Sense (Single)	.100 breakaway header mates with Molex 22-55-2061 or equivalent crimp terminal housing with Molex type 71851 or equivalent crimp terminal.
P3	Power Fail (Multiple)	.100 breakaway header mates with Molex 50-57-9002 or equivalent crimp terminal housing with Molex type 71851 or equivalent crimp terminal.

RECOMMENDED AIR FLOW DIRECTION

